

AIM[®]

Automatic Machines

CATALOG 2026

INDEX

COMAPNY	4	SPAZIO RANGE	46
ORIGINS	4	SLIM ATHENA	52
REVOLUTION	5	MEDIUM ATHENA	54
PHILOSOPHY	6	SLIM SPARTAN	56
TEAM	7	MEDIUM SPARTAN	58
AM CLUB	8		
ATHENA RANGE	10	INDOOR	62
EXTRA	16	SELF INDOOR	64
MEDIUM	18		
SLIM	20	ICE RANGE	66
SMALL	22	SANDEN 60	68
WALL MEDIUM	24	SANDEN 48	70
WALL SLIM	26	SANDEN 36	72
WALL SMALL	28	AD6	74
		AD4	76
SPARTAN RANGE	32	ICE 18	78
EXTRA	38		
MEDIUM	40	ACCESSORIES	80
SLIM	42	OPTIONAL EXTRAS	81

The information and configurations shown in this catalogue are indicative and may be subject to change. Please refer to the digital version for any updates.



Scan the QR code and discover all **AM Automatic Machines** updates online in real time.

Origins

AM traces its roots back to a simple place: the workshop.

Many years ago, Marco Piovani began his professional journey in his father's workshop, a compact space of just 200 square metres, where coffee vending machines were refurbished for a multinational company. Those modest premises proved to be a fundamental learning ground, providing him with **invaluable experience and a deep understanding of mechanics, electronics and electrotechnics.**

After years of work and continuous improvement, at the dawn of his forties, Marco Piovani seized the opportunity for a major change, **giving rise to AM Automatic Machines.** The company quickly established itself on the market, becoming a **leading player in the vending industry, with over 25 years of innovation behind it.**

Over the years, AM's mission has been **to make vending machines more accessible, secure and efficient,** combining cutting-edge technology, hands-on field experience and a strong customer focus.

These objectives are reflected in the company's core values, where **ethics, respect and transparency are not optional, but the foundation of every relationship and project.** Operating responsibly and placing the needs of both customers and end users at the centre are essential principles.

1999 - Foundation

AM Automatic Machines Srl is founded, an Italian company specialising in innovative vending machines.

2008 - New Headquarters

Relocation to San Zeno Naviglio (BS), into an 8,000 m² facility, increasing production capacity and operational space.

2003/2004

AM becomes the first company in Italy to integrate a card reader into vending machines, enabling age control, user identification and credit receipt printing.

The Vending Machine Revolution

Growth has been steady.

AM's growth path has been constant and driven by a clear vision: innovating by breaking conventions.

From the very beginning, the company stood out for its ability to anticipate market trends. The first clear example came with the market launch of the Bull vending machines, push-button models characterised by their iconic red colour, which quickly became a benchmark in the sector.

Between **2003 and 2004, AM was the first company in Italy to integrate a card reader into vending machines**, introducing new possibilities for user identification and age verification. In 2008, the company moved to its headquarters in San Zeno Naviglio (BS), an industrial facility of over 8,000 m² dedicated to design and production.

In 2013, Touch Bull was released, replacing buttons with a **touchscreen monitor and transforming the vending machine into a true multi-service system** capable of managing online top-ups and advanced functions. In 2017, **AM Club was introduced: the digital platform** that allows tobacconists to remotely monitor and manage data, accounting and updates via app or web.

Two years later, with **EGO**, AM introduced artificial intelligence into vending machines, **enabling voice recognition and contactless sales management**. This **ongoing evolution goes beyond technology** and is reflected in the way AM approaches work, quality and customer relationships.

2017 - AM Club

AM Club is launched, the digital platform that allows tobacconists to manage vending machines remotely, including data, accounting and updates, via both mobile app and web.

Today

AM continues to strengthen its position as a key reference point in the tobacco market, offering tobacconists innovative and reliable solutions designed to enhance both their business and daily operations.

2024/2025

The Athena and Spartan product lines are launched: two highly advanced and innovative solutions capable of meeting every market requirement.

Philosophy: Precision, Accuracy and Listening

Success stems from the discipline of Marco Piovani, built on precision, accuracy and attentive listening to customers.

The company **relies on 100% in-house know-how**, ensuring that every innovation, from the **creative phase through to development**, is the result of internal teams' work.

This approach is based on over 25 years of direct field experience and translates into advanced, reliable products designed to meet real market needs.

Total quality is ensured through **state-of-the-art production processes**, including the introduction of the "production line concept" to improve productivity and precision, along with a rigorous selection and traceability methodology that guarantees the highest standards for every component.

As a final seal of this commitment, **every vending machine is thoroughly tested** before leaving the factory.

Our numbers



+17.000

AM vending machines installed



+80

Employees



+70

Agents and technicians



+10

AM patents

Human relationships beyond the machine

Product care extends to customer care, as AM positions itself as a unique 360° partner.

Customer support guides clients throughout the entire life cycle of their vending machine, with **services ranging from Customer Care to fast technical assistance**, ensured by a widespread network of specialised technicians across Italy.

Although guided support systems are available, the company continues to value human interaction in order to fully understand every specific need.

Operational reliability is guaranteed by a structured system of software and firmware updates, keeping every machine constantly efficient and up to date. In line with this approach, AM provides **AM Club, the digital portal that allows tobacconists to manage their vending machines remotely, and AM Shop**, the platform dedicated to the direct and fast purchase of original spare parts, ensuring maximum efficiency and operational continuity.

AM also boasts long-standing strategic collaborations, such as the partnership with BCC RENT&LEASE, which over more than 10 years has enabled the approval of over 13,000 financing applications for the purchase of vending machines.

An **AM product** is therefore much more than a vending machine: **it is a reliable partner that supports tobacconists in the growth of their business.**

Design
and production

Assistance
and customer care

Installation
and start-up



AM Club: your machine, your business. Always under control.

AM Club is the free portal reserved for AM customers, designed to offer maximum control and maximum simplicity in managing vending machines.

A true management platform, accessible from any device, allowing real-time monitoring of all machine activities, data analysis, service activation and optimisation of every aspect of the business.

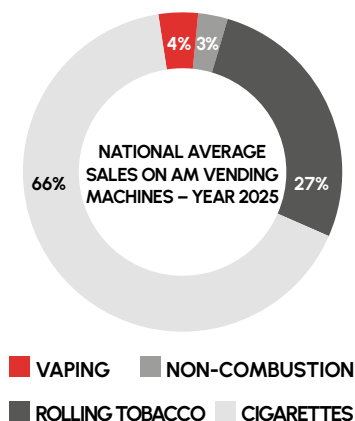

Vaping: a growth opportunity for vending machine

Increasing margins and revenues of up to 30%: 2025 data confirms the strategic value of vaping products.

The tobacco market is undergoing a significant transformation, and optimising the product portfolio has become essential to maximise vending machine profitability.

In 2025, national data shows that vaping products generated on average **over 16% of total vending machine margins**.

Customers who anticipated this **trend now report up to 30% of total revenues coming from vaping products**, demonstrating the strategic impact of a targeted and up-to-date offering.

Focusing on the most profitable products is essential.

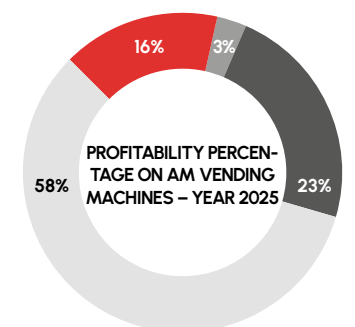

Discover AM Club



Anti-dispute webcam

The product delivery webcam protects the tobacconist: every sale can be verified in **AM Club**, preventing disputes.



Real-time updates

With the Sales Events section of **AM Club**, every vending machine operation is recorded and available in real time.

POS Payment have surpassed cash!

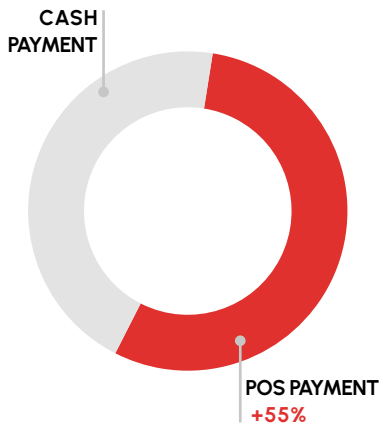

On AM vending machines equipped with POS devices, in 2025 electronic payments exceeded cash transactions. The trend is clear: POS payments accounted for over 55% of total transactions.

POS = more sales, more profits. Statistics don't lie: AM vending machines equipped with POS record significantly higher sales compared to those accepting cash only.

The introduction of electronic payments is the key factor in significantly increasing turnover.

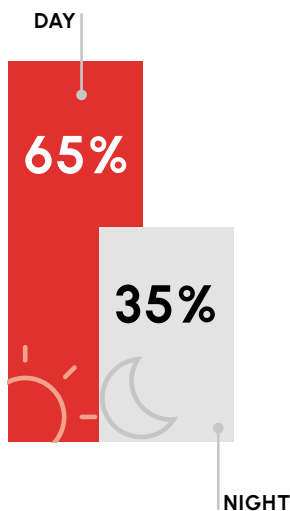

Your AM vending machine sells all the time!

AM vending machines have recorded a clear change in customer purchasing habits thanks to their superior ease and speed of use.

National average sales 2025:

Daytime = 65%

Night-time = 35%

Do you still think vending machines sell more at night?



Available on the App Store and Google Play



Accounting under control

With automatic fiscal reports, the shop's accounting is always under control.



Always connected

With AM Club chat, we are always in touch: a direct channel with us for any questions or requests.

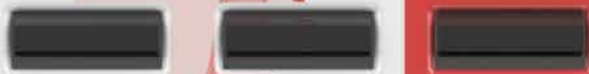

AREA

18



SCONTRINO



IMPRONTA
E TESSERA



BANCONOTE



MONETE



BANCONOTE



ATHENA

SCANNER



CARTE E
BANCOMAT

AM
Automatic Machines

PRODOTTO E RESTO



ATHENA

Advanced vending machine with
vertical column layout.





ATHENA

Available in **8** different sizes

Up to **181** selections

Up to **1,545** packs

Athena, more selections, more products, more margin.

Athena is the vending machine designed to optimise space based on actual product rotation: more capacity where it is needed, greater efficiency for the point of sale.

Higher capacity for high-demand items and targeted configuration for lower-rotation products: a design logic that reduces restocking operations and ensures continuous product availability.

The mechanical structure, refined over time, guarantees stable performance and simplified operation, even under high usage volumes.



More selections

Optimised internal space based on real sales data: more autonomy where it matters, less waste where it doesn't.

More products

Optimisation frees up space to introduce new items: alternative products, accessories and special formats.

More margin

Increasing the number of selections also increases profitability: offering a wider product range boosts vending machine revenue.

Reliable dispensing for every product.

A solution designed to simplify work, automate management and increase business profitability.

From the G-BOX experience comes an even smarter system.

This new vertical-column vending machine inherits the solidity and reliability of G-BOX, while optimising every aspect: more order, more efficiency, more technology.

Dispensing time: 2.5 seconds

Athena is designed for those who manage their point of sale every day with precision and close attention to numbers.

Every design choice is based on concrete data, the result of years of field experience and in-depth market analysis.

More space for best-selling products, less waste, greater efficiency: a solid and rational structure that ensures continuity and availability.





Configurations and options.

Thanks to the available services, **Athena** is not just a vending machine, but a true service hub for the point of sale.

It allows customers to access much more than a simple purchase: mobile top-ups and prepaid cards, bill payments, legal betting services, digital product sales and much more — all in a single secure and intuitive station.

With Athena, the store's offering expands, management is simplified and a fast, complete service is guaranteed 24/7.

ATHENA EXTRA



Up to **181 selections**





Up to **1545 packs**

Configurations

FIT	Motor units	Spirals	G&V	Total selections
Configuration A	124	5	Max 9	138
Configuration B	119	5	Max 9	133
Configuration C	114	5	Max 9	128

WIDE	Motor units	Spirals	G&V	Total selections
Configuration A	167	5	Max 9	181
Configuration B	159	5	Max 9	173
Configuration C	151	5	Max 9	165

Technical specifications

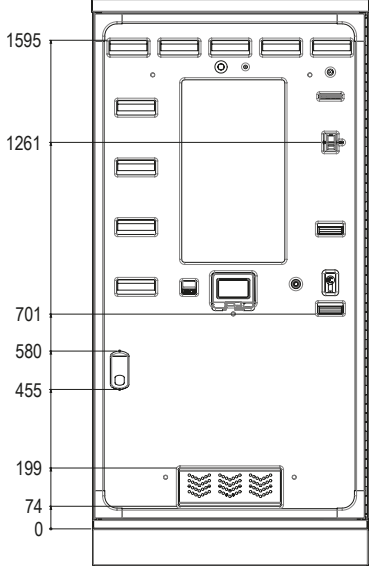
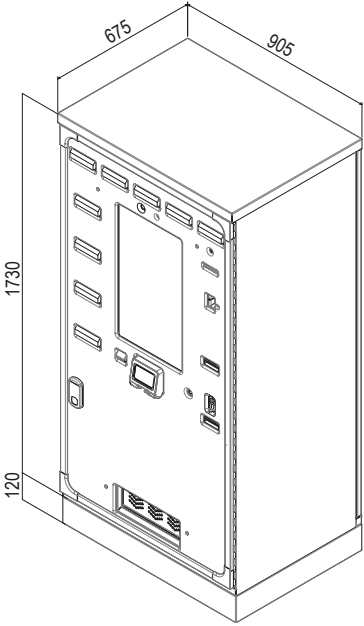
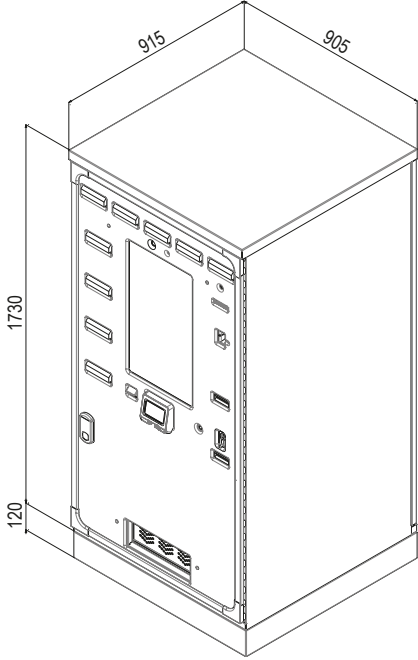
	FIT	WIDE
 DIMENSIONS	W 905 x H 1850 x D 675 mm	W 905 x H 1850 x D 915 mm
 WEIGHT	365 kg	430 kg
 POWER	125 W Max	125 W Max
 MONITOR SIZE	27"	27"
		



GREY COLOUR VARIANT



VAPING VARIANT



MACHINE OPEN

ATHENA MEDIUM







Up to 141 selections

Up to 1121 packs

FIT	Motor units	Spirals	G&V	Total Selections
Configurations A	102	5	Max 3	110
Configurations B	97	5	Max 3	105
Configurations C	92	5	Max 3	100

WIDE	Motor units	Spirals	G&V	Total Selections
Configurations A	133	5	Max 3	141
Configurations B	125	5	Max 3	133
Configurations C	117	5	Max 3	125

Technical specifications

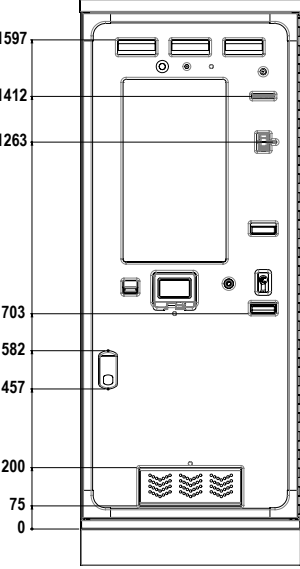
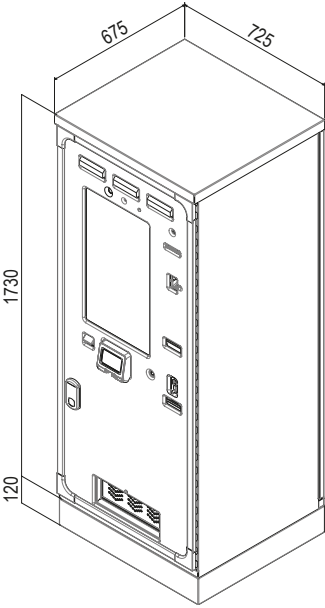
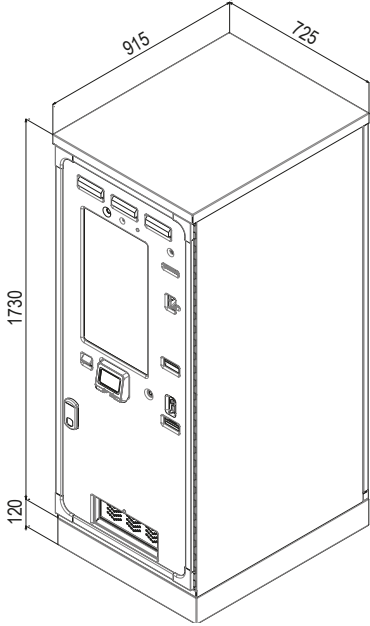
	FIT	WIDE
 DIMENSIONS	W 725 x H 1850 x D 675 mm	W 725 x H 1850 x D 915 mm
 WEIGHT	285 kg	335 kg
 POWER	125 W Max	125 W Max
 MONITOR SIZE	27"	27"
		



GREY COLOUR VARIANT



VAPING VARIANT



MACHINE OPEN



Up to **128 selections**





Up to **1057 packs**

Configurations

FIT	Motor units	Spirals	G&V	Total Selections
Configurations A	88	5	Max 2	95
Configurations B	83	5	Max 2	90
Configurations C	78	5	Max 2	85

WIDE	Motor units	Spirals	G&V	Total Selections
Configurations A	121	5	Max 2	128
Configurations B	113	5	Max 2	120
Configurations C	105	5	Max 2	112

Technical specifications

	FIT	WIDE
 DIMENSIONS	W 555 x H 1850 x D 675 mm	W 555 x H 1850 x D 915 mm
 WEIGHT	250 kg	295 kg
 POWER	125 W Max	125 W Max
 MONITOR SIZE	27"	27"

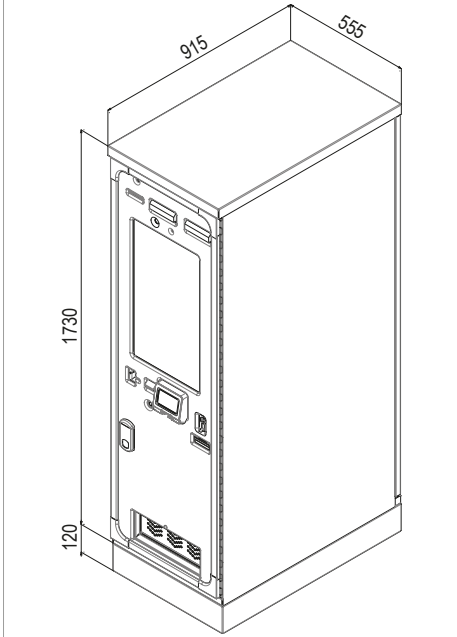
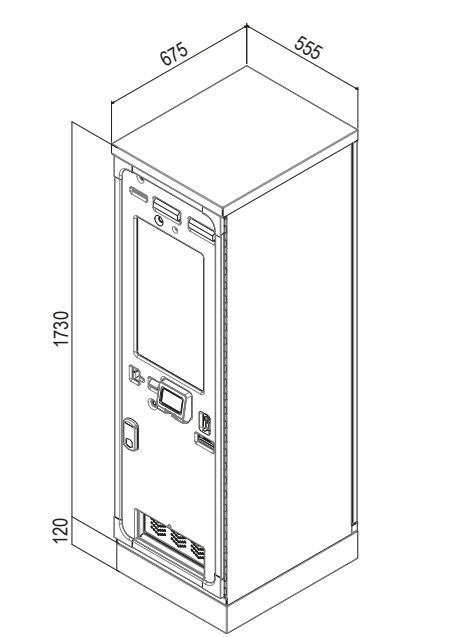
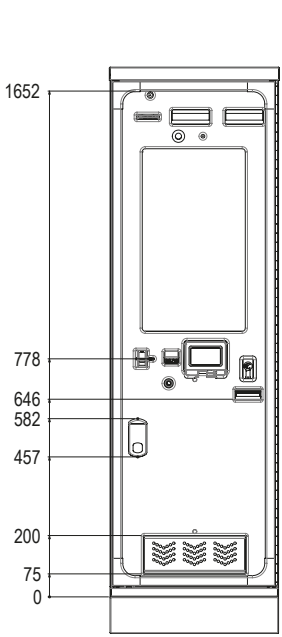

GREY COLOUR VARIANT



VAPING VARIANT



MACHINE OPEN

ATHENA SMALL







Up to **66 selections**

Up to **465 packs**

Configurations

FIT	Motor units	Spirals	G&V	Total Selections
Configurations A	54	6	Max 4	64
Configurations B	47	6	Max 4	57
Configurations C	52	10	Max 4	66

Technical specifications

 DIMENSIONS	W 725 x H 1250*x D 475 mm
 WEIGHT	170 kg
 POWER	125 W Max
 MONITOR SIZE	27"

* Attention: the height of the vending machine with base is H 1850 mm

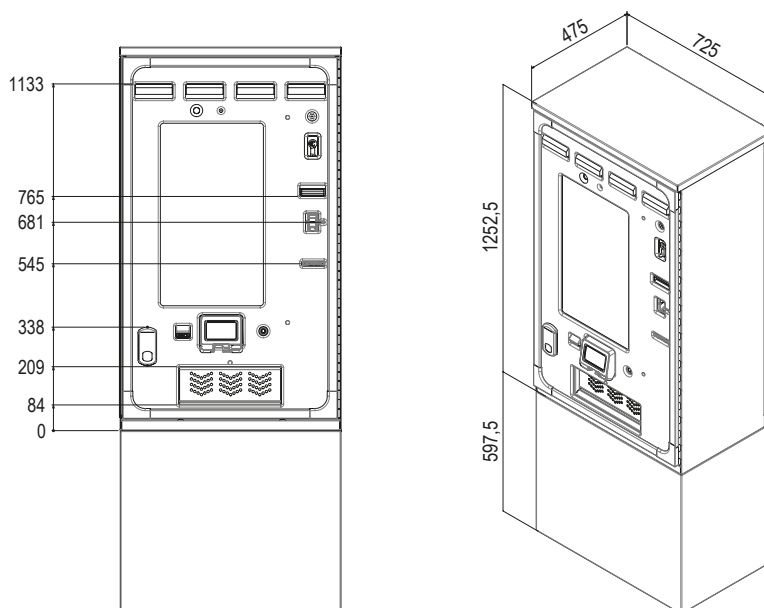

GREY COLOUR VARIANT



VAPING VARIANT



MACHINE OPEN

ATHENA WALL MEDIUM



Up to **153 selections**





Up to **1365 packs**

Configurations

FIT	Motor units	Spirals	G&V	Total Selections
Configurations	120	6	Max 2	128

WIDE	Motor units	Spirals	G&V	Total Selections
Configurations	145	6	Max 2	153

Technical specifications

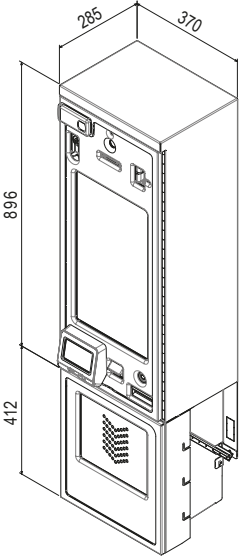
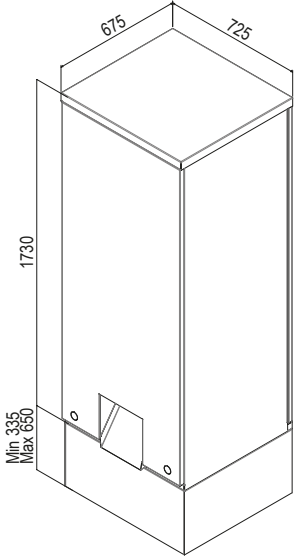
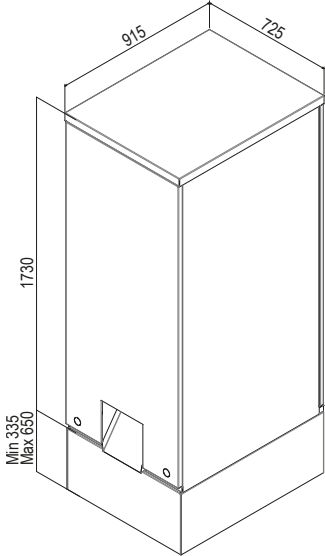
	CONTROL PANEL	FIT STORAGE MODULE	WIDE STORAGE MODULE
 DIMENSIONS*mm	W 370 x H 1308 x D 285	W 725 x H 1730x D 675	W 725 x H 1730x D 915
 WEIGHT	80 kg	285 kg	335 kg
 POWER	125 W Max	-	-
 MONITOR SIZE	21,5"	-	-
			

*Specifications do not include the G&V module



GREY COLOUR VARIANT



VAPING VARIANT



OPEN STORAGE UNIT

ATHENA WALL SLIM



Up to **129** selections





Up to **1166** packs

Configurations

FIT	Motor units	Spirals	G&V	Total Selections
Configurations	94	6	Max 2	102

WIDE	Motor units	Spirals	G&V	Total Selections
Configurations	121	6	Max 2	129

Technical specifications

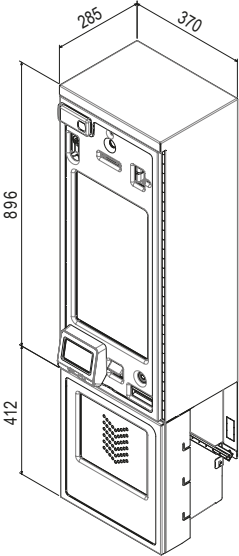
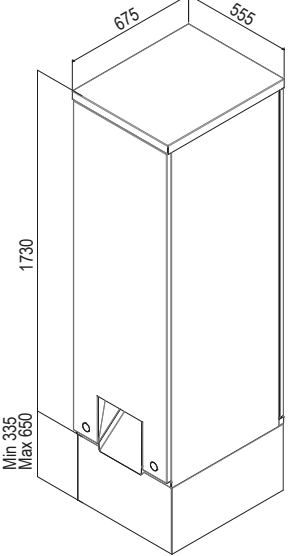
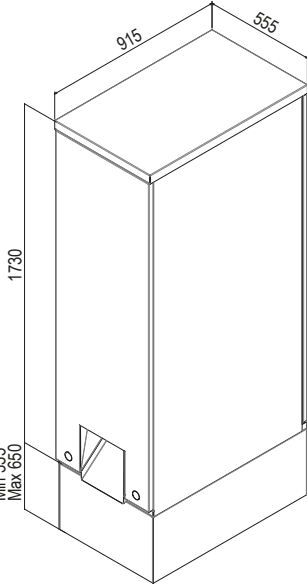
	CONTROL PANEL	FIT STORAGE MODULE	WIDE STORAGE MODULE
 DIMENSIONS* mm	W 370 x H 1308 x D 285	W 555 x H 1730x D 675	W 555 x H 1730x D 915
 WEIGHT	80 kg	250 kg	295 kg
 POWER	125 W Max	-	-
 MONITOR SIZE	21,5"	-	-
			

*Specifications do not include the G&V module



GREY COLOUR VARIANT



VAPING VARIANT



OPEN STORAGE UNIT

ATHENA WALL SMALL







Up to **71** selections

Up to **576** packs

Configurations

	Motor units	Spirals	G&V	Total Selections
Configurations A	63	6	Max 2	71

Technical specifications

	CONTROL PANEL	STORAGE MODULE
 DIMENSIONS*	L 370 x H 1308 x D 285 mm	W 725 x H 1253 x D 474 mm
 WEIGHT	80 kg	170 kg
 POWER	125 W Max	-
 MONITOR SIZE	21,5"	-

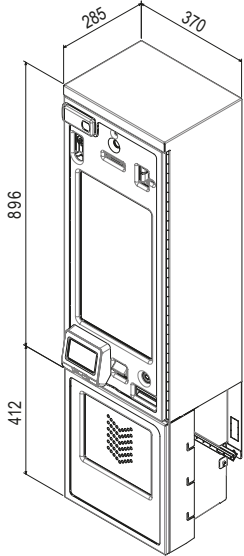
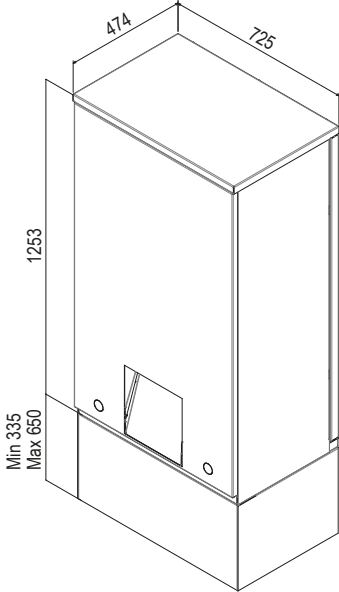
	
--	--

*Specifications do not include the G&V module



GREY COLOUR VARIANT



VAPING VARIANT



OPEN STORAGE UNIT

Product column configuration



	EXTRA			EXTRA WIDE			MEDIUM			MEDIUM WIDE		
CONFIGURATIONS	A	B	C	A	B	C	A	B	C	A	B	C
4 pouches	5	5	5	5	5	5	5	5	5	5	5	5
5 standard	30	20	15	62	48	41	20	10	5	46	32	25
5 100's	36	36	36	30	30	30	36	36	36	30	30	30
5 pouches	4	4	4	4	4	4	4	4	4	4	4	4
7 100's	6	6	6	6	6	6	6	6	6	6	6	6
7 non-combustion	17	17	17	19	19	19	17	17	17	19	19	19
9 non-combustion	2	2	2	4	4	4	2	2	2	4	4	4
11 standard												
13 standard	15	20	15	20	26	18	10	15	10	12	18	10
15 non-combustion												
18 non-combustion	10	10	10	16	16	16	5	5	5	8	8	8
21 standard			5			7			5			7
30 standard				2	1	1				2	1	1
48 standard				4	5	5				2	3	3
57 standard	4	4	4				2	2	2			
TOTAL COLUMNS	129	124	119	172	164	156	107	102	97	138	130	122
TOTAL PACKS	1152	1167	1182	1511	1537	1545	833	848	863	1087	1113	1121



SLIM			SLIM WIDE			SMALL			WALL				
A	B	C	A	B	C	A	B	C	MEDIUM	MEDIUM WIDE	SLIM	SLIM WIDE	SMALL
5	5	5	5	5	5	6	6	10	6	6	6	6	6
20	10	5	46	32	25	17	3	17	29	49	20	40	3
24	24	24	20	20	20	8	8	8	36	30	24	20	18
4	4	4	4	4	4	4	4	4	4	4	4	4	4
4	4	4	4	4	4				6	6	4	4	
17	17	17	19	19	19	8	8	8	17	19	17	19	8
2	2	2	4	4	4				2	4	2	4	
						9	9	7					22
10	15	10	12	18	10		7		10	10	10	10	
						8	8	8					8
5	5	5	8	8	8				5	8	5	8	
		5			7				5	7	5	7	
			2	1	1				4	5	1	2	
			2	3	3					3		3	
2	2	2							2		2		
93	88	83	126	118	110	60	53	62	126	151	100	127	69
759	774	789	1023	1049	1057	444	465	438	1107	1365	898	1166	567

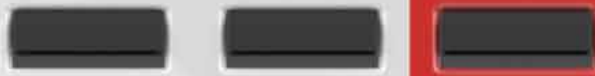

AREA



SPARTAN

SCONTRINO



IMPRONTA E TESSERA



BANCONOTE



MONETE



BANCONOTE



SCANNER



CARTE E BANCOMAT



PRODOTTO E RESTO



SPARTAN

Horizontal drawer structure
for fast and secure restocking.





SPARTAN

Available in 6 different sizes
Up to 144 selections
Up to 2,990 packs

Large spaces, great flexibility, maximum reliability.

Every detail of Spartan is designed to simplify daily management: from the accessible internal layout, to fast maintenance, and the intuitive interface.

It is an essential machine, designed to operate in the field without unnecessary complexity. A concrete solution for those looking for reliable, practical equipment built around the real needs of the point of sale..



Flexible

Quick configuration for all product types, including non-standard packaging.

Convenient

Simple loading and immediate access: fewer errors, less time wasted.

Immediate

Independent motor system: eliminates total blockages and ensures continuous operation.

Product size is not a limitation.

With Spartan, it is possible to manage different types of packaging.

The horizontal drawer structure and its modular components allow the dispensing of products with varying formats and sizes, optimizing distribution even for significantly different packages.

Dispensing time: 1.5 seconds

Spartan revolutionizes the refilling process thanks to the horizontal drawer layout, making every operation intuitive and convenient.

No effort and no wasted time: each drawer can be easily extracted, allowing products to be loaded in an orderly and fast manner.

Change, move, and adapt with complete ease.

Spartan is designed to quickly adapt to the needs of an evolving market, thanks to a modular system of configurable drawers.

The horizontal design makes refilling operations simple, fast, and intuitive, minimizing the effort required. No special tools, no complications: just functionality serving everyday efficiency.





SPARTAN EXTRA







Up to **144 selections**

Up to **2990 packs**

Configurations

FIT/WIDE	Motor units	Spirals	G&V	Total Selections
Configurations A	124	5	Max 9	138
Configurations B	126	5	Max 9	140
Configurations C	126	5	Max 9	140
Configurations D	122	5	Max 9	136
Configurations E	130	5	Max 9	144

Technical specifications

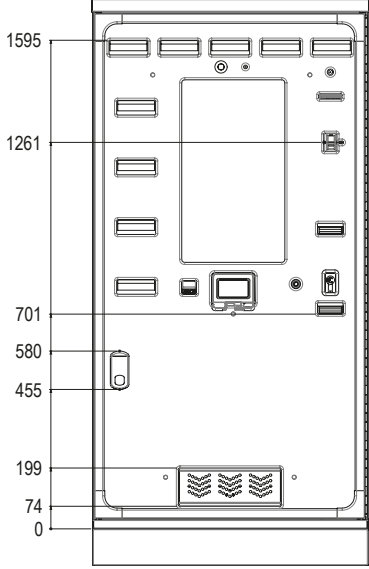
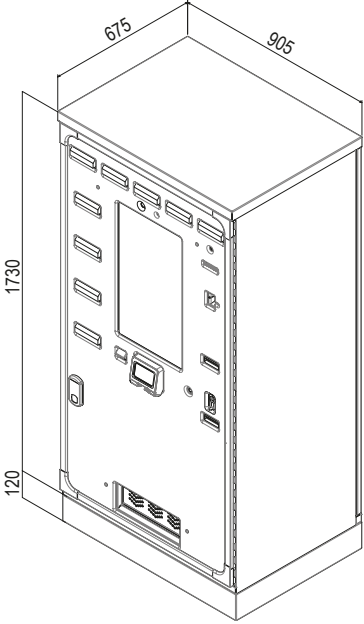
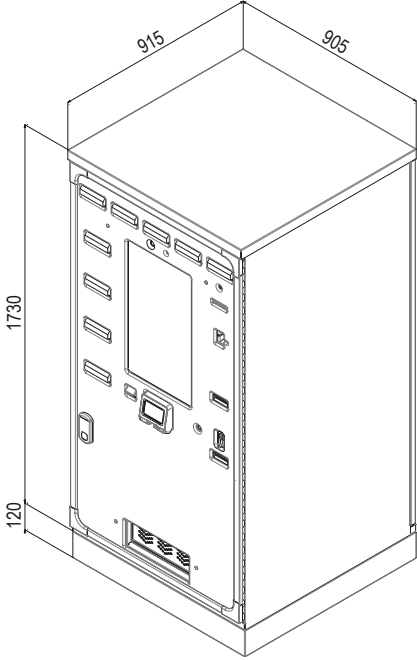
	FIT	WIDE
 DIMENSIONS	W 905 x H 1850 x D 675 mm	W 905 x H 1850 x D 915 mm
 WEIGHT	365 kg	435 kg
 POWER	125 W Max	125 W Max
 MONITOR SIZE	27"	27"
		



GREY COLOUR VARIANT



VAPING VARIANT



MACHINE OPEN

SPARTAN MEDIUM







Up to 106 selections

Up to 2250 packs

Configurations

FIT/WIDE	Motor units	Spirals	G&V	Total Selections
Configurations A	94	5	Max 3	102
Configurations B	95	5	Max 3	103
Configurations C	95	5	Max 3	103
Configurations D	93	5	Max 3	101
Configurations E	98	5	Max 3	106

Technical specifications

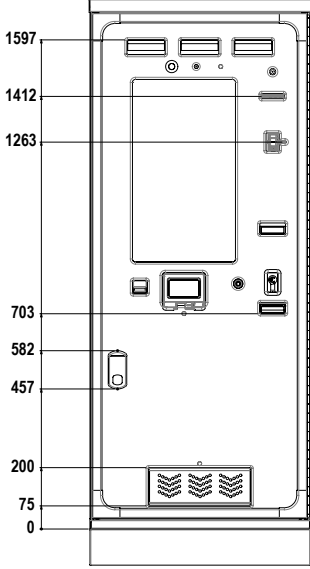
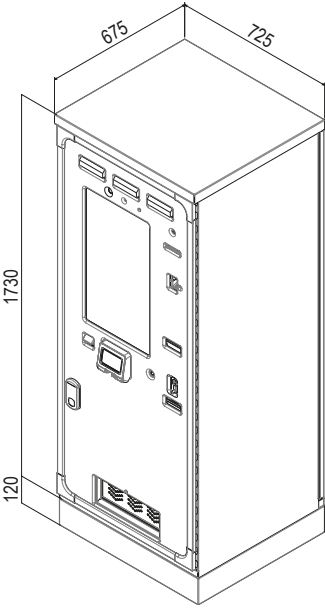
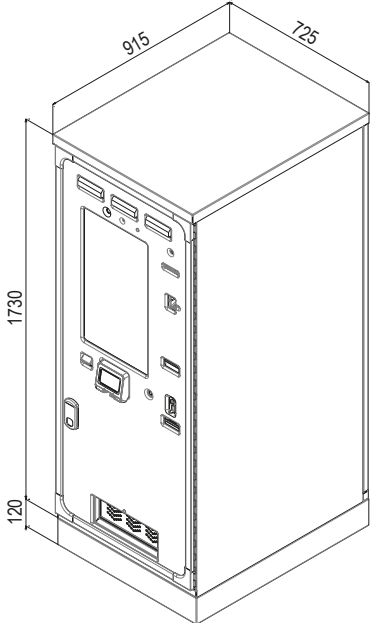
	FIT	WIDE
 DIMENSIONS	W 725 x H 1850 x D 675 mm	W 725 x H 1850 x D 915 mm
 WEIGHT	305 kg	370 kg
 POWER	125 W Max	125 W Max
 MONITOR SIZE	27"	27"
		



GREY COLOUR VARIANT



VAPING VARIANT



MACHINE OPEN

SPARTAN SLIM







Up to **78** selections

Up to **1620** packs

Configurations

FIT/WIDE	Motor units	Spirals	G&V	Total Selections
Configurations A	67	5	Max 2	74
Configurations B	68	5	Max 2	75
Configurations C	68	5	Max 2	75
Configurations D	66	5	Max 2	73
Configurations E	71	5	Max 2	78

Technical specifications

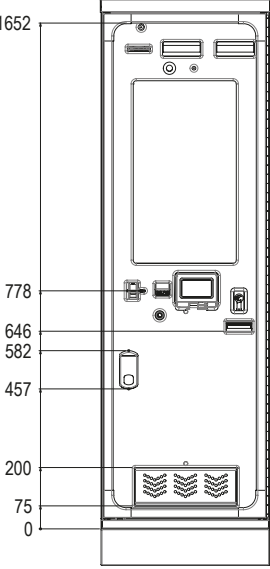
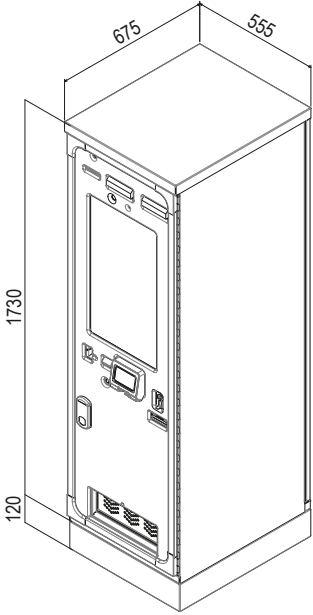
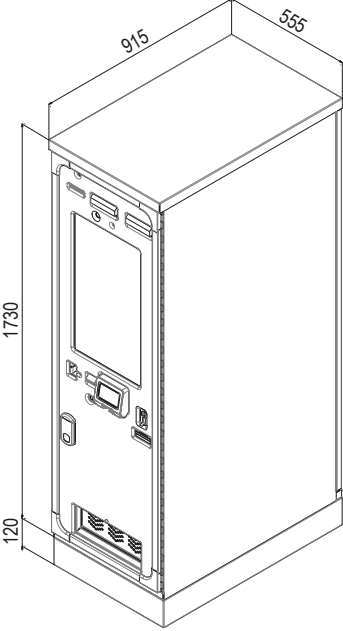
	FIT	WIDE
 DIMENSIONS	W 555 x H 1850 x D 675 mm	W 555 x H 1850 x D 915 mm
 WEIGHT	255 kg	305 kg
 POWER	125 W Max	125 W Max
 MONITOR SIZE	27"	27"
		



GREY COLOUR VARIANT



VAPING VARIANT



MACHINE OPEN

Product column configuration



DRAWER TYPE	CONFIGURATIONS					NO. OF SELECTIONS PER DRAWER			PACK CAPACITY PER SELECTION	
	A	B	C	D	E	SLIM	MEDIUM	EXTRA	FIT	WIDE
Non-combustible products	2	3	3	1	2	8	11	15	15	30
Standard	4	3	4	5	3	7	10	13	10	20
100's	2	2	1	2	1	7	10	13	10	20
Disposable sticks	1	1	1	1	2	9	12	16	10	20
10 ml liquids	0	0	0	0	1	9	12	16	10	20
Pouches	1	1	1	1	1	5	5	5	4	4







SPAZIO

SPAZIO

The **expansion module** that allows you to increase profitability.





SPAZIO

Available in 8 different sizes

Up to 148 selections

Up to 2.278 packs

Spazio: more capacity, tailored to your needs.

SPAZIO is the expansion module designed to increase capacity, flexibility, and optimization of the master machine, both Athena and Spartan.

The master unit, whether Athena or Spartan, can be combined with one or two Spazio modules, creating a high-capacity, flexible, and customized hybrid configuration.

Adding Spazio allows the creation of a complete and well-organized product range, designed to maximize efficiency and profitability at the point of sale.



Simple and intuitive

Spazio is an expansion module fully integrable with Athena or Spartan master machines.

Flexibility and/or optimization

Available with horizontal drawers or vertical columns to optimize the configuration of the vending machine.

Reliable

The Spazio module uses technologies derived from the Athena and Spartan ranges.



Vertical columns.

Technology derived from the Athena range.

The vertical column layout leverages space optimization based on the actual product rotation.

This allows efficient assortment management with targeted capacity, ensuring continuity, reducing restocking operations, and improving overall availability and performance at the point of sale.





Horizontal drawers.

Technology derived from the Spartan range.

The horizontal drawer configuration is designed to handle non-standard formats and packaging with maximum flexibility.

This solution simplifies loading and maintenance operations, facilitating adaptation to different operational requirements and ensuring consistent efficiency.



**SPAZIO
SLIM
ATHENA**



Up to **130** selections



Up to **1057** packs

Configurations

FIT	Motor units	Spirals	G&V	Total Selections
Configurations A	88	5	Max 4	97
Configurations B	83	5	Max 4	92
Configurations C	78	5	Max 4	87

WIDE	Motor units	Spirals	G&V	Total Selections
Configurations A	121	5	Max 4	130
Configurations B	113	5	Max 4	122
Configurations C	105	5	Max 4	114

Technical specifications

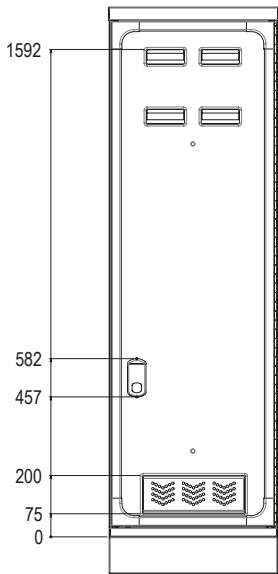
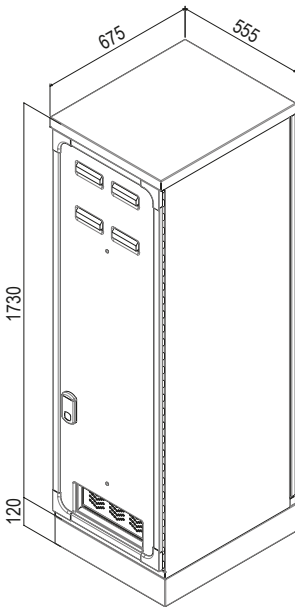
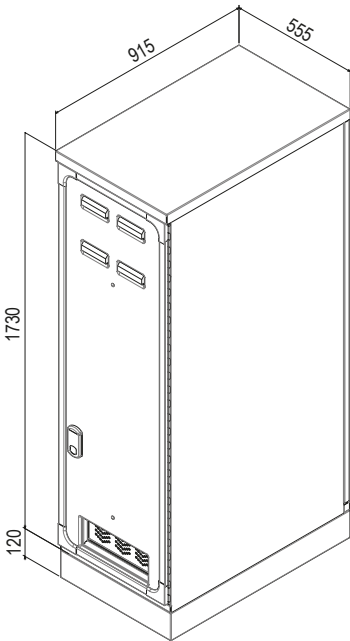
	FIT	WIDE
 DIMENSIONS	W 555 x H 1850 x D 675 mm	W 555 x H 1850 x D 915 mm
 WEIGHT	235 kg	280 kg
 POWER	125 W Max	125 W Max
		



GREY COLOUR VARIANT



VAPING VARIANT



MACHINE OPEN

**SPAZIO
MEDIUM
ATHENA**



Up to **148 selections**



Up to **1149 packs**

Configurations

FIT	Motor units	Spirals	G&V	Total Selections
Configurations A	102	12	Max 3	117
Configurations B	97	12	Max 3	112
Configurations C	92	12	Max 3	107

WIDE	Motor units	Spirals	G&V	Total Selections
Configurations A	133	12	Max 3	148
Configurations B	125	12	Max 3	140
Configurations C	117	12	Max 3	132

Technical specifications

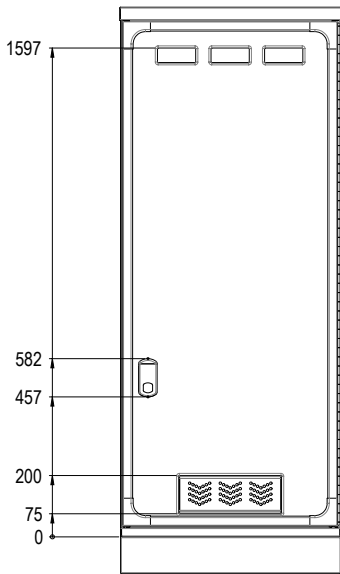
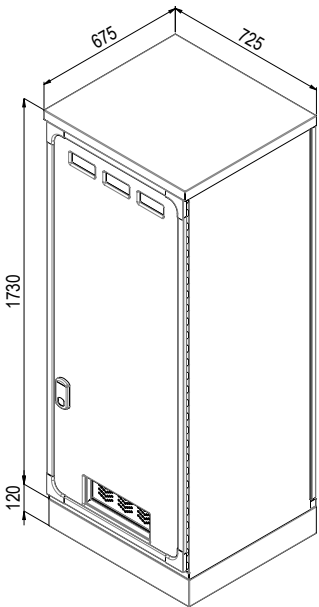
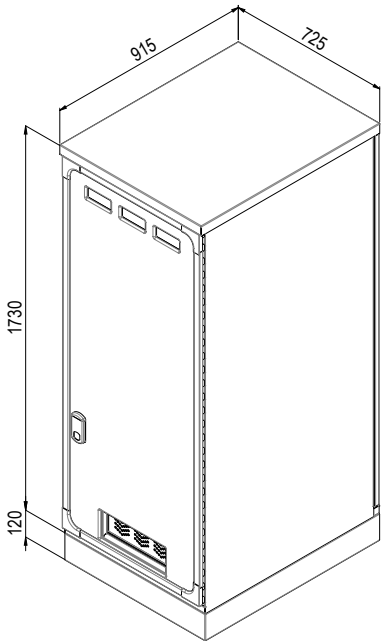
	FIT	WIDE
 DIMENSIONS	W 725 x H 1850 x D 675 mm	W 725 x H 1850 x D 915 mm
 WEIGHT	255 kg	305 kg
 POWER	125 W Max	125 W Max
		



 GREY COLOUR VARIANT



 VAPING VARIANT



MACHINE OPEN

**SPAZIO
SLIM
SPARTAN**





Up to **80 selections**

Up to **1620 packs**

Configurations

FIT/WIDE	Motor units	Spirals	G&V	Total Selections
Configurations A	67	5	Max 4	76
Configurations B	68	5	Max 4	77
Configurations C	68	5	Max 4	77
Configurations D	66	5	Max 4	75
Configurations E	71	5	Max 4	80

Technical specifications

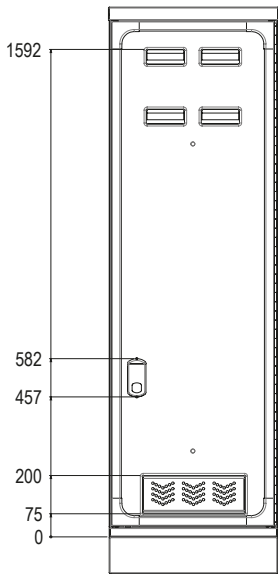
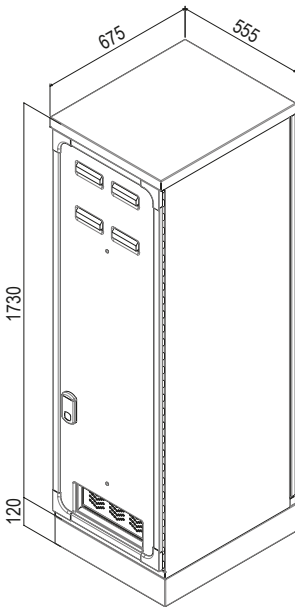
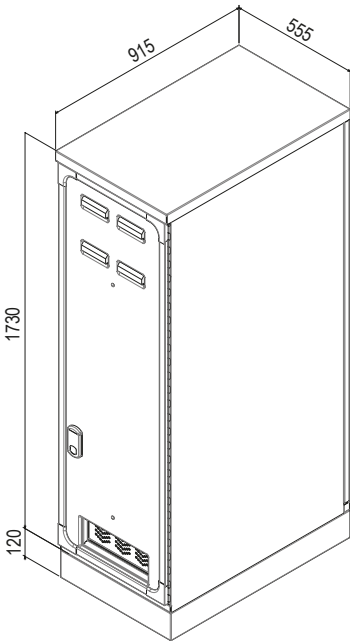
	FIT	WIDE
 DIMENSIONS	W 555 x H 1850 x D 675 mm	W 555 x H 1850 x D 915 mm
 WEIGHT	265 kg	305 kg
 POWER	125 W Max	125 W Max
		



GREY COLOUR VARIANT



VAPING VARIANT



MACHINE OPEN

SPAZIO
MEDIUM
 SPARTAN





Up to **113 selections**

Up to **2278 packs**

Configurations

FIT/WIDE	Motor units	Spirals	G&V	Total Selections
Configurations A	94	12	Max 3	109
Configurations B	95	12	Max 3	110
Configurations C	95	12	Max 3	110
Configurations D	93	12	Max 3	108
Configurations E	98	12	Max 3	113

Technical specifications

	FIT	WIDE
 DIMENSIONS	W 725 x H 1850 x D 675 mm	W 725 x H 1850 x D 915 mm
 WEIGHT	275 kg	340 kg
 POWER	125 W Max	125 W Max

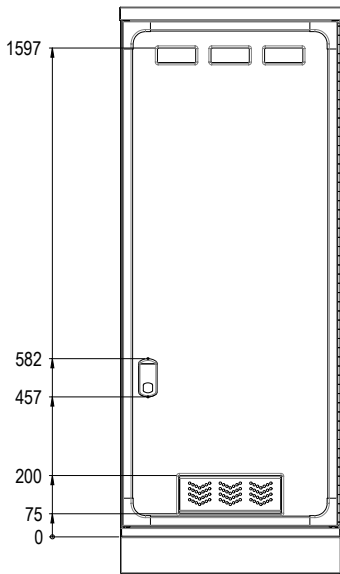

1597
582
457
200
75
0

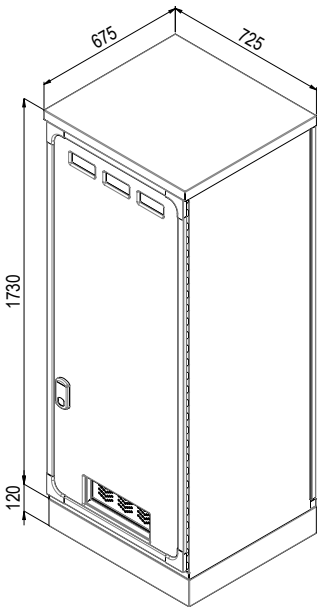

675
725
1730
120

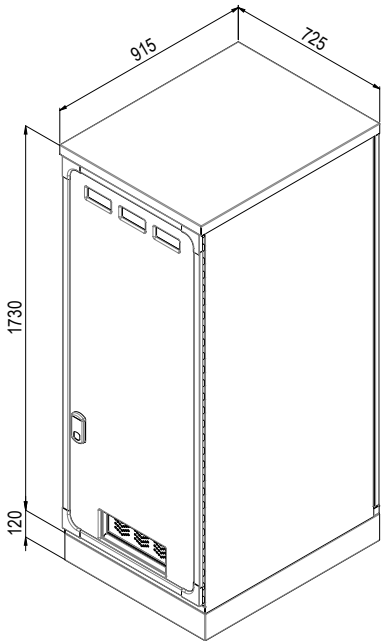

915
725
1730
120



GREY COLOUR VARIANT



VAPING VARIANT



MACHINE OPEN

Product configuration – vertical columns



CONFIGURATIONS	SPAZIO SLIM FIT VERTICAL COLUMNS			SPAZIO SLIM WIDE VERTICAL COLUMNS			SPAZIO MEDIUM FIT VERTICAL COLUMNS			SPAZIO MEDIUM WIDE VERTICAL COLUMNS		
	A	B	C	A	B	C	A	B	C	A	B	C
4 Pouches	5	5	5	5	5	5	12	12	12	12	12	12
5 Standard	20	10	5	46	32	25	20	10	5	46	32	25
5 100's	24	24	24	20	20	20	36	36	36	30	30	30
5 Pouches	4	4	4	4	4	4	4	4	4	4	4	4
7 100's	4	4	4	4	4	4	6	6	6	6	6	6
7 Non-combustible products	17	17	17	19	19	19	17	17	17	19	19	19
9 Non-combustible products	2	2	2	4	4	4	2	2	2	4	4	4
11 Standard												
13 Standard	10	15	10	12	18	10	10	15	10	12	18	10
15 Non-combustible products												
18 Non-combustible products	5	5	5	8	8	8	5	5	5	8	8	8
21 Standard			5			7			5			7
30 Standard				2	1	1				2	1	1
48 Standard				2	3	3				2	3	3
57 Standard	2	2	2				2	2	2			
TOTAL COLUMNS	93	88	83	126	118	110	114	109	104	145	137	129
TOTAL PACKS	759	774	789	1023	1049	1057	861	876	891	1115	1141	1149

Product configuration - Horizontal drawers



DRAWER TYPE	NUMBER OF DRAWERS PER CONFIGURATION					SPAZIO SLIM FIT HORIZONTAL DRAWERS	SPAZIO SLIM WIDE HORIZONTAL DRAWERS
	A	B	C	D	E	CAPACITY PACKS PER SELECTION	CAPACITY PACKS PER SELECTION
Pouches	5	5	5	5	5	4	4
Non-combustible	2	3	3	1	2	15	30
Standard	4	3	4	5	3	10	20
100's	2	2	1	2	1	10	20
Disposable sticks	1	1	1	1	2	10	20
10 ml liquids	0	0	0	0	1	10	20
TOTAL PACKS FIT	772	820	820	720	810		
TOTAL PACKS WIDE	1520	1620	1620	1420	1600		



TIPO CASSETTO	NUMBER OF DRAWERS PER CONFIGURATION					SPAZIO MEDIUM FIT HORIZONTAL DRAWERS	SPAZIO MEDIUM WIDE HORIZONTAL DRAWERS
	A	B	C	D	E	CAPACITY PACKS PER SELECTION	CAPACITY PACKS PER SELECTION
Buste	5	5	5	5	5	4	4
No Combustione	2	3	3	1	2	30	30
Standard	4	3	4	5	3	20	20
100'S	2	2	1	2	1	20	20
Usa & Getta Sticks	1	1	1	1	2	20	20
Liquidi 10ml	0	0	0	0	1	20	20
TOTALE PACCHETTI FIT	1098	1163	1163	1133	1138		
TOTALE PACCHETTI WIDE	2148	2278	2278	2018	2228		

INDOOR

Self Indoor is an advanced solution designed for tobacconists who want to optimize the management of over-the-counter product sales.

It automates the dispensing of packs, eliminates queues, and allows the tobacconist to fully focus on managing the point of sale, without wasting time on repetitive manual operations.

It is not a simple display that takes up space, but a fully automated display integrated into the store, capable of generating value, improving the customer experience, and creating new profitability.



INDOOR SELF INDOOR



Up to **294** selections





Up to **3270** packs

Configurations

ATHENA	Motor units	Spirals	G&V	Total Selections
Configurations A	92	6	-	98
Configurations B	88	6	-	94

SPARTAN	Motor units	Spirals	G&V	Total Selections
Configurations C	98	0	-	98
Configurations D	90	6	-	96
Configurations E	86	8	-	94

Technical specifications

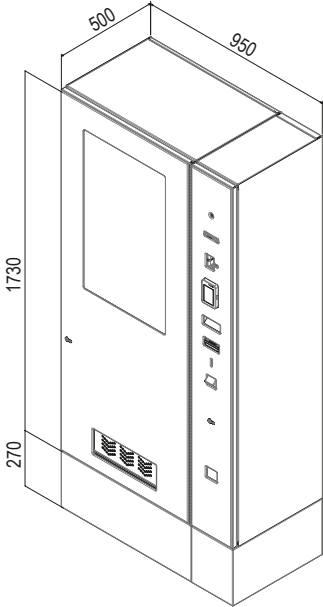
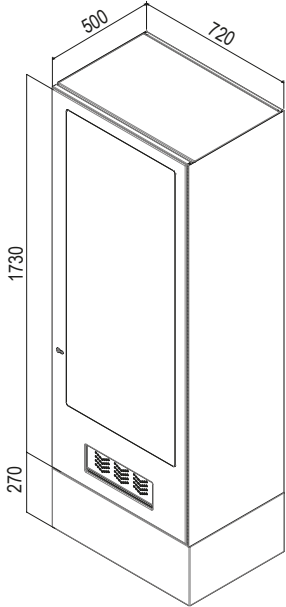
	MASTER	SLAVE
 DIMENSIONS* mm	W 950 x H 1730x D 500	W 720 x H 1730 x D 500
 WEIGHT	210 kg	180 kg
 POWER	125 W Max	-
 MONITOR SIZE	32"	-
		



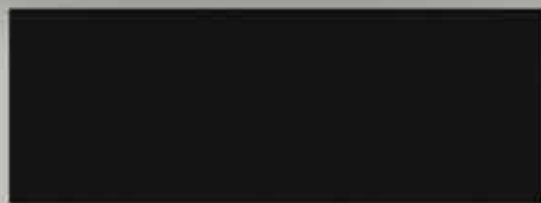



Expand your vending machine offering with the **ICE refrigerated range**, ensuring snacks and beverages are always available.



ICE SANDEN 60



60 selections

Configurations

DRAWERS	Spirals	Pitch	Spiral capacity	Product examples
Drawer 1	10	30	14	Rolling tobacco / snacks
Drawer 2	10	30	14	Rolling tobacco / snacks
Drawer 3	10	35	12	Rolling tobacco / snacks
Drawer 4	7	45	10	Chips / juices
Drawer 5	10	77	6	Bottles / cans
Drawer 6	10	77	6	Cans

Technical specifications

 DIMENSIONS	W 980 x H 1850 x D 910 mm
 WEIGHT	330 kg
 POWER	350 W Max

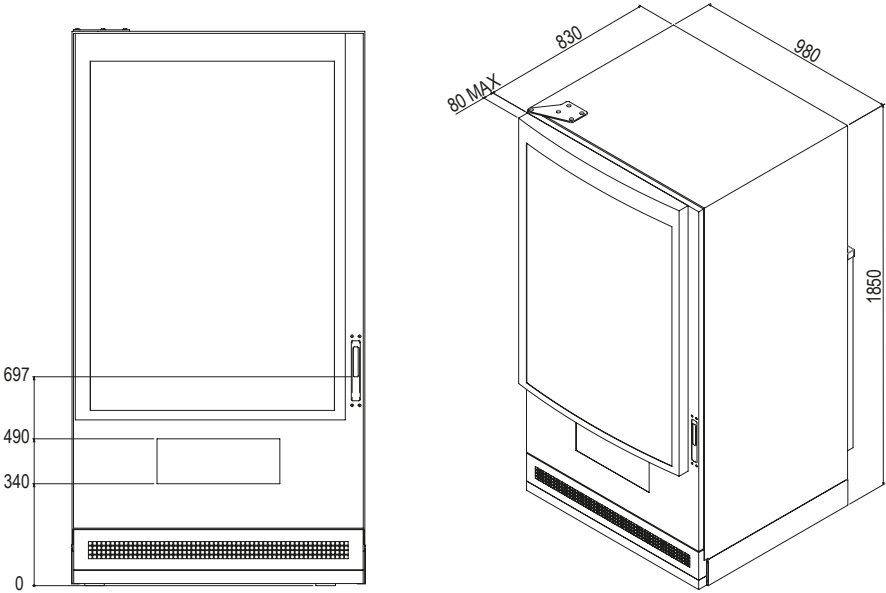

COMPATIBLE WITH ATHENA



COMPATIBLE WITH SPARTAN

ICE SANDEN 48



48 selections

Configurations

DRAWERS	Spirals	Pitch	Spiral capacity	Product examples
Drawer 1	8	30	14	Rolling tobacco / snacks
Drawer 2	8	30	14	Rolling tobacco / snacks
Drawer 3	8	35	12	Rolling tobacco / snacks
Drawer 4	6	45	10	Chips / juices
Drawer 5	8	77	6	Bottles / cans
Drawer 6	8	77	6	Cans

Technical specifications

 DIMENSIONS	W 830 x H 1850 x D 910 mm
 WEIGHT	280 kg
 POWER	350 W Max

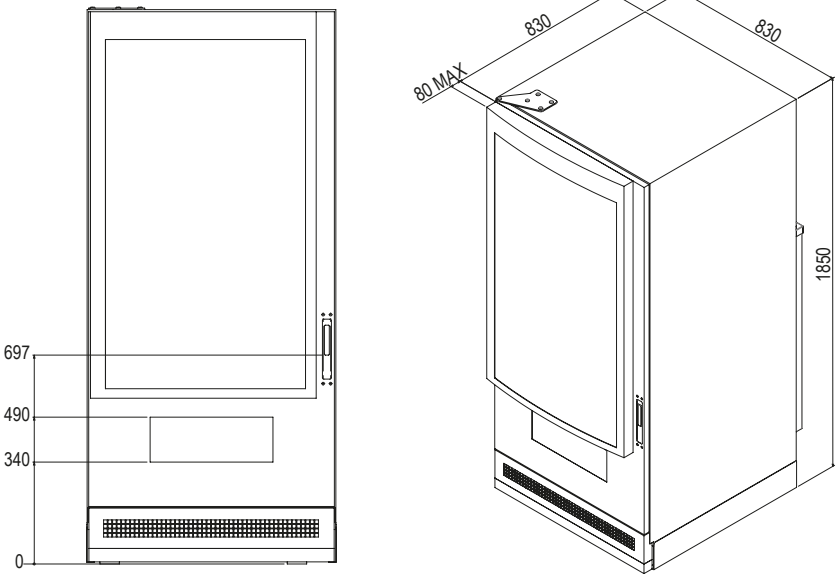

COMPATIBLE WITH ATHENA



COMPATIBLE WITH SPARTAN

ICE SANDEN 36





36 selections

Configurations

DRAWERS	Spirals	Pitch	Spiral capacity	Product examples
Drawer 1	6	30	14	Rolling tobacco / snacks
Drawer 2	6	30	14	Rolling tobacco / snacks
Drawer 3	6	35	12	Rolling tobacco / snacks
Drawer 4	5	45	10	Chips / juices
Drawer 5	6	77	6	Bottles / cans
Drawer 6	6	77	6	Cans

Technical specifications

 DIMENSIONS	W 685 x H 1850 x D 910 mm
 WEIGHT	240 kg
 POWER	350 W Max

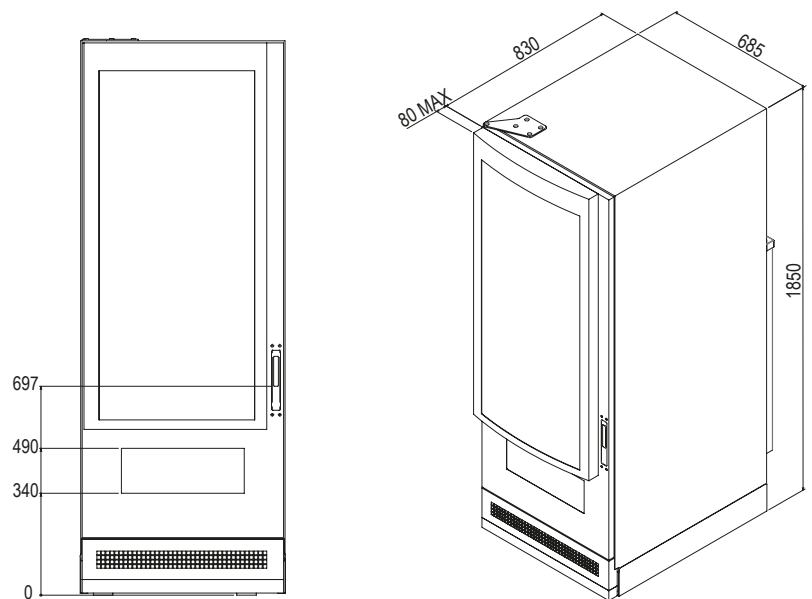

COMPATIBLE WITH ATHENA



COMPATIBLE WITH SPARTAN

IC AD6





36 selections

Configurations

DRAWERS	Spirals	Pitch	Spiral capacity	Product examples
Drawer 1	6	26	8	Rolling tobacco / snacks
Drawer 2	6	26	8	Rolling tobacco / snacks
Drawer 3	6	26	8	Rolling tobacco / snacks
Drawer 4	5	52	4	Chips / juices
Drawer 5	6	77	3	Bottles / cans
Drawer 6	6	77	3	Cans

Technical specifications

 DIMENSIONS	W 590 x H 1850 x D 600 mm
 WEIGHT	155 kg
 POWER	230 W Max

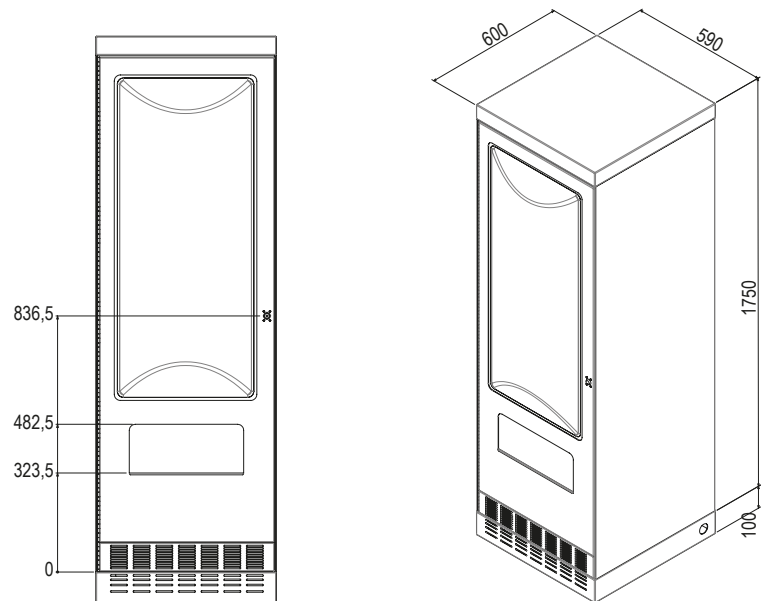

COMPATIBLE WITH ATHENA



COMPATIBLE WITH SPARTAN

IC AD4





24 selections

Configurations

DRAWERS	Spirals	Pitch	Spiral capacity	Product examples
Drawer 1	4	26	8	Rolling tobacco / snacks
Drawer 2	4	26	8	Rolling tobacco / snacks
Drawer 3	4	26	8	Rolling tobacco / snacks
Drawer 4	4	52	4	Chips / juices
Drawer 5	4	77	3	Bottles / cans
Drawer 6	4	77	3	Cans

Technical specifications

 DIMENSIONS	W 425 x H 1850 x D 600 mm
 WEIGHT	155 kg
 POWER	230 W Max

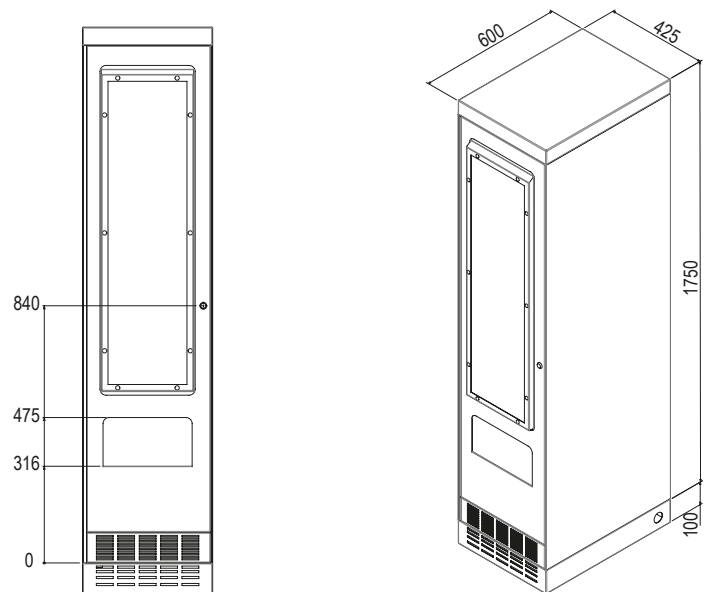

COMPATIBLE WITH **ATHENA**



COMPATIBLE WITH **SPARTAN**

ICE 18





18 selections

Configurations

DRAWERS	Spirals	Pitch	Spiral capacity	Product examples
Drawer 1	3	26	8	Rolling tobacco / snacks
Drawer 2	3	26	8	Rolling tobacco / snacks
Drawer 3	3	52	4	Rolling tobacco / snacks
Drawer 4	3	77	3	Chips / juices
Drawer 5	3	77	3	Bottles / cans
Drawer 6	3	77	3	Cans

Technical specifications

 DIMENSIONS	W 350 x H 1850 x D 600 mm
 WEIGHT	140 kg
 POWER	230 W Max

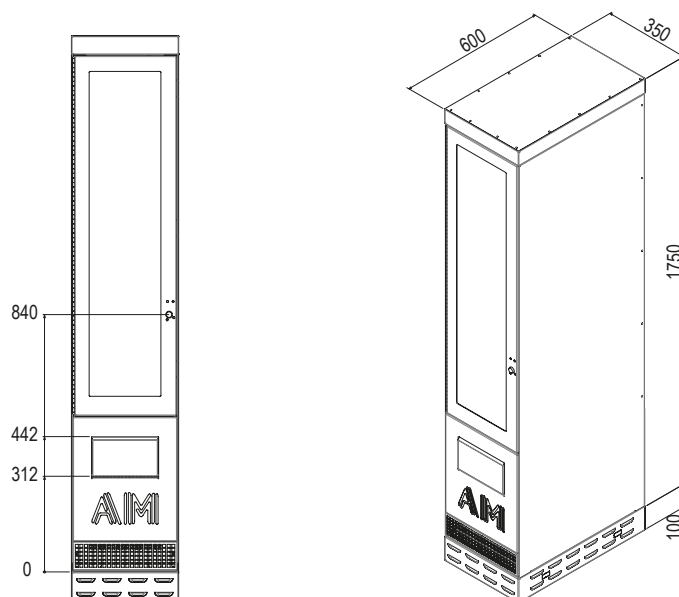



COMPATIBLE WITH ATHENA





COMPATIBLE WITH SPARTAN

Standard accessories and services included

 **Intelligent serial LEDs**
Dynamic visual effects that attract attention and guide the customer step by step for an intuitive and uninterrupted purchasing experience.

 **Magnetic lock cover**
Easy and convenient door opening thanks to the magnetic key, which also ensures maximum security.

 **Controlled ventilation system**
Keeps the display at the ideal temperature by automatically activating cooling fans when temperatures rise.

 **Courtesy light**
LEDs illuminate the inside of the machine during product loading and cash collection operations.

 **Proximity sensor**
Detects the presence of the customer and activates the purchase guidance process and other functions.

 **Thermal printer**
Thermal printer with automatic cutter for issuing credit receipts, receipts, top-ups, and bills. Compact and high-speed.

 **Banknote reader**
Self-aligning banknote reader, remotely upgradable, with a 400-banknote stacker.

 **Self-recharging change giver**
Self-recharging change giver with patented PEC technology for coin discrimination and an innovative sonar system for measuring coin levels in the tubes, designed to be immune to dirt.

 **Card reader**
Card reader with contact chip and magnetic stripe.

 **Accelerometer**
Detects abnormal movements, identifying fraud and tampering, triggering alarms and recording suspicious events to prevent theft and vandalism.

 **Alarm webcam**
Records video in the event of a vending machine alarm and immediately sends an attached file with the recording.

 **Cybersecurity**
Cybersecurity is at the core of AM's philosophy. Our commitment to security ensures data protection and strengthens customer trust in our products and services.

 **Quick purchase**
Product selection via camera using barcode recognition (requires OCR device).

 **Updates**
Automatic updates for software, products, prices, and services.

 **Visual Broadcast**
Thanks to an exclusive partnership with Philip Morris, the Visual Broadcast service can be activated on AM vending machines, allowing promotional videos to be displayed in exchange for compensation.

 **Peripheral firmware update**
Updates for banknote and coin readers to detect counterfeits and support new ECB banknotes.

 **LIS online top-ups**
Mobile top-ups, purchase codes, international cards, and digital TV services.

 **LIS bill payments**
Pre-marked bills and PagoPA payments (requires PAX POS device).

 **Mr Pay**
Betting account top-ups, cryptocurrency sales, and cryptocurrency payments.

 **Betpassion / Betwin360**
Betting credit top-up service (AM exclusive).

 **Satispay**
Digital payment system independent of cards.

 **Fiscal data transmission**
Automatic transmission of fiscal data to the Italian Revenue Agency.

 **Remote vending machine control**
AM Club – management and remote control of the vending machine via web portal and Android / iOS app.

Functions & Accessories (Optional)



POS

Device for accepting Credit Card and PagoBancomat payments, both contactless and card insertion.



Energy saving

Intelligent adaptation to ambient lighting, resulting in significant energy savings and reduced operating costs.



Product delivery webcam

Camera in the product delivery area to eliminate disputes related to non-dispensed products. Video available in AM Club.



OCR reader

OCR, barcode, and QR code (1D and 2D) recognition device for quick purchases, bill payments, and rechargeable receipts.



Vocal control

Voice assistant allowing users to pronounce the desired product name. Artificial intelligence continuously optimizes the purchasing process.



Photocells

Product delivery detection and certification device to prevent disputes over non-dispensed products.



Fingerprint reader

Fingerprint identification module for customer loyalty. Stores only an anonymous ID, not traceable to the user, ensuring maximum privacy.



Second banknote reader

Additional self-aligning, remotely upgradable banknote reader with a 400-banknote stacker (available only on Extra and Medium models).



Self-diagnostics

During cash collection, signals every movement with voice alerts, visual alerts, and app notifications, preventing errors caused by distractions.



Talking column

Eliminates errors and simplifies column loading through voice guidance with the name of the product to be loaded.



Automatic vendor

AM patented software designed to prevent stockouts, suggest alternatives, display out-of-stock products, and provide reports with configuration recommendations.



Additional hopper

Additional dispenser supporting the change giver (max 1 for Medium and max 2 for Extra).



Electronic wallet

Cashless product purchases and identity verification via fingerprint.



Rechargeable receipt

Credit receipt with a unique identification code that customers can redeem directly at the vending machine.



Stainless steel option

Machine body made of stainless steel for installations exposed to salt air.



Automatic Machines



Automatic Machines

AM Automatic Machines SRL a Socio Unico
Soggetta a direzione e coordinamento
di Piemme Invest S.r.l.

Via Brunelleschi 1, 25010 San Zeno Naviglio (BS)
Tel. + 39 030 2106933 | Fax. +39 0302106806
P.IVA 03513890172



info@gruppo-am.com

www.gruppo-am.com

Facebook: [AutomaticMachines](#)

Instagram: [@am.automatic.machines](#)

